

NOTE 1)

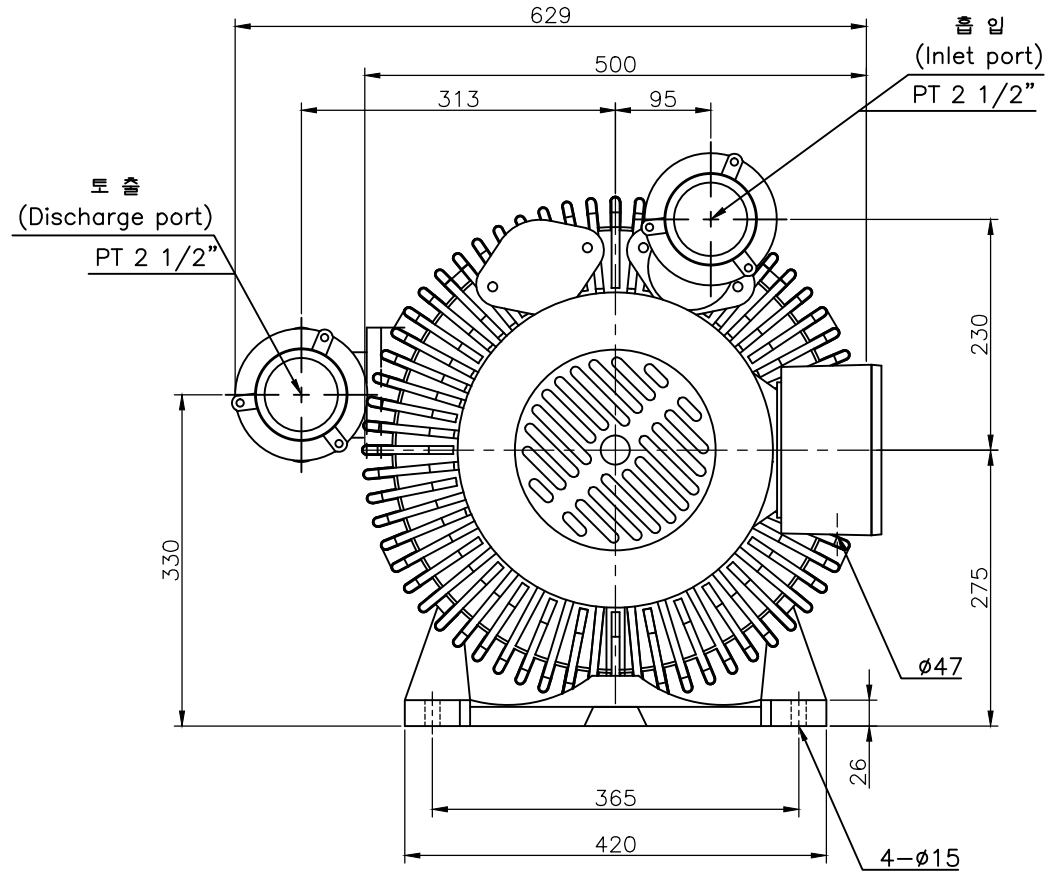
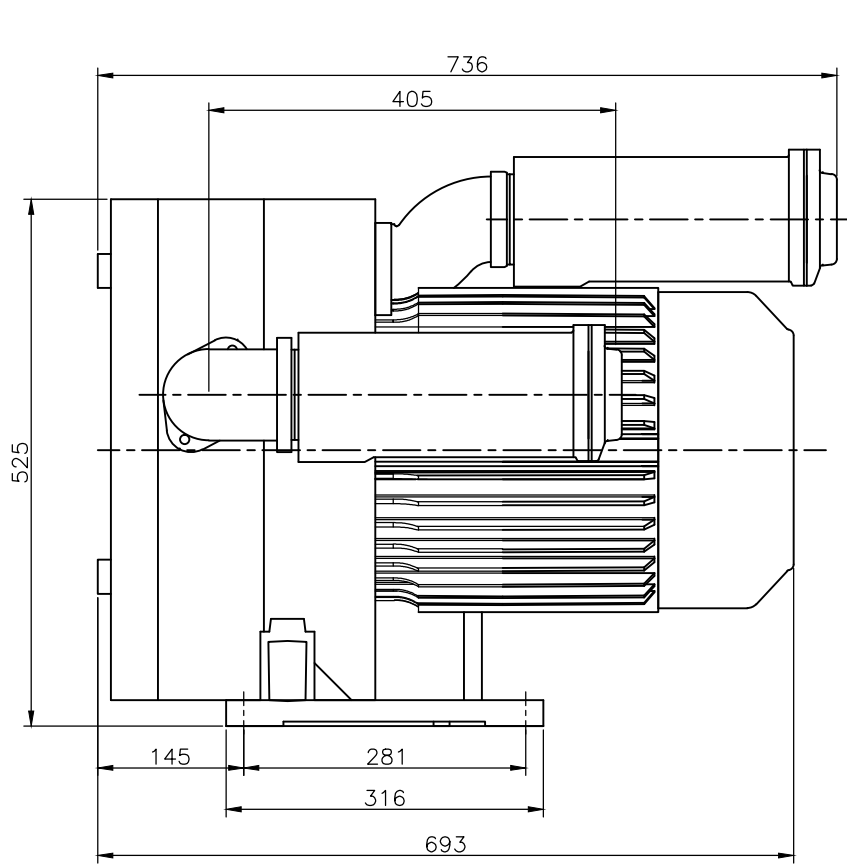

△																			
△																			
No.		Revision		Date		Draw		Check		Appr.									
보통 치수 허용차	회주제품 주조				절삭 가공				형식 TYPE		HRB-1102 MH		도명 TITLE		OUTLINE DWG				
	길이		두께		치수 구분		정밀급	보통급	DRAWN	DESIGN	CHECKED	APPROVED	3RD ANGLE	SCALE:1/NS	UNIT:mm				
	치수 구분	허용차	치수 구분	허용차	0 - 6	±0.05	±0.1		B.S.Kim				SIZE	3ø 2P 13.2Kw					
	0 - 120	±1.5	0 - 10	±1.5	6 - 30	±0.1	±0.2		11.06.08										
	120 - 250	±2.0	10 - 18	±2.0	30 - 120	±0.15	±0.3												
250 - 400	±3.0	18 - 30	±3.0	120 - 315	±0.2	±0.5													
400 - 500	±4.0	30 - 50	±3.5	315 - 1000	±0.3	±0.6													
500 - 1800	±6.0			1000 - 2000	±0.5	±1.2							도번 DWG. No		BOD00190		△		
				2000 - 3150	±0.8	±1.6							黃海電機 HWANG HAE ELECTRIC						